

Experiment and analysis of water droplet wettability on superhydrophobic surfaces manipulated by electric field

Qingcheng Wang*, Yi Lou, Deqing Zhang, and Xiaodong Yang

School of Mechanical and Vehicle Engineering, Jilin Engineering Normal University, Changchun, China

Abstract. Electric field manipulates the change of droplets wettability on superhydrophobic surfaces, which is widely used in many fields such as electronic zoom microlens and electro wetting displays, and has an important research value. This paper prepared a superhydrophobic acetate film applied electrostatic spinning technique, the maximum contact angle of acetate film is 152.6° , conducted electric field-regulated water droplet wettability change tests, applied voltage to water droplets on acetate film. It was found that the contact angle of the droplets decreased with the increase of the electric field strength, and the electric field regulated the contact angle of the droplets to change in the range of $92.7-142.3^\circ$. When the power supply is turned off, the contact angle of the droplet can gradually recover, but not completely restored to the original state.

1 Introduction

Wetting is the process by which gases are replaced by liquids on a solid surface and is one of the most common phenomena in nature. Contact Angle (CA) is an important parameter to measure the wettability of solid surfaces, surfaces with $CA > 90^\circ$ are called hydrophobic surfaces, and the larger the contact angle the stronger the hydrophobicity. Recent decades of research have shown that the microstructure and chemical composition are the intrinsic factors affecting the wettability of solid surfaces, and the excitation signals such as electric field, magnetic field, temperature, and light are the external factors affecting the wettability of solid surfaces^[1-2]. As a quick and easy way to induce external stimuli, electric field transformation shows unique advantages in the regulation of material surface wettability. The reversible regulation of material surface wettability makes it widely used in many fields^[3-4], such as electronic zoom microlenses and electrically wetted displays^[5-7].

This paper intend to prepare a kind of superhydrophobic dielectric layer, and carry out the droplet modulation test with electric field to explore the changing law of droplet wettability and electric field strength.

*Corresponding author: wqc9341@163.com

2 Superhydrophobic surface preparation experimental

Electrostatic spinning is a simple and efficient spinning process capable of applying various polymer solutions to fabricate nanofibers^[8]. This process of preparing nanofibers has many advantages, such as low cost, simple and efficient process, and easy control of the structure and size of the nanofibers^[9]. In this experiment, we mainly used low surface energy cellulose acetate (CH₂O₄) as the material and prepared superhydrophobic fiber film by electrostatic spinning and depositing it on the glass surface.

2.1 Experimental equipment and materials

The test equipment include: Electrostatic Spinning Machine(HD-2335), Micro Analytical Balance(GH-252), Scanning electron microscope(S4800), Contact angle Measuring Instrument(DSA100). The test materials include: Cellulose acetate(39.8%), Acetone(Analytical purity),Chloroform CHCl₃ (Analytical purity).

2.2 Experimental methods and procedures

(1) Spinning solution preparation, weighing a certain mass of cellulose acetate, add a certain amount of solvent V acetone /DMAC=3:2, respectively, formulated with a mass fraction of 8 wt%, 10 wt%, 12 wt%, 14 wt%, 16 wt%, 18 wt%, 20 wt%, 22 wt% of the solution. At the same time with different volume ratios V acetone /DMAC=4:1, V acetone /DMAC=2:1, V acetone /DMAC=3:2, V acetone /DMAC=2:2, V acetone /DMAC=1:2, V acetone / water=4:1, V acetone / chloroform = 4:1 of the solvent mixture to formulate a 12 wt% cellulose acetate solution, stirring at room temperature for 4h, static, so that the solvent and the Solute dissolved fully, electrostatic spinning to spare.

(2) For the electrostatic spinning of cellulose acetate solution, the electro spinning solution obtained from the above configuration was injected into a 10mL plastic syringe with a metal needle at a room temperature of 25°C and a humidity of less than 50%. The syringe was fixed on the syringe pump, the spinning voltage was controlled at 12-18kV, the advance rate of the spinning solution was 0.1-1.5 mm/min, the distance between the nozzle and the receiving mounting plate was maintained at 10-30 cm, and the glass was used for receiving during the spinning process.

(3) The contact angle of each acetate film was measured by applying a contact angle meter with a water droplet volume of 5μL, and the range of the contact angle was measured to be 134.5-152.6°. When the contact angle was 152.6°, the microstructure of the acetate film was observed with a scanning electron microscope as shown in Fig. 1.

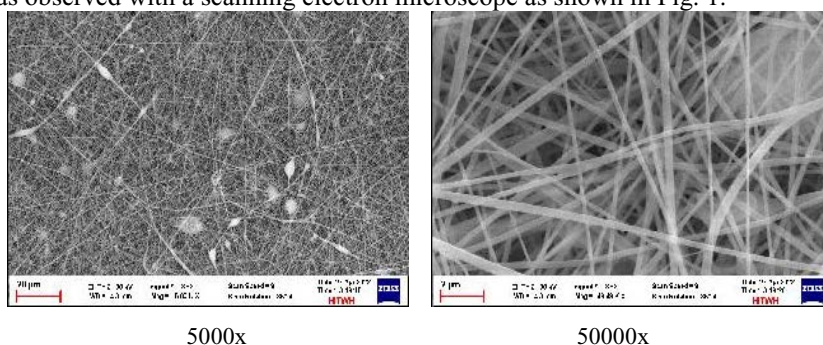

Fig. 1. Scanning electron micrographs of acetate films.

3 Electric field manipulation droplet experimental

3.1 Experimental equipment

The experimental setup is shown in Fig. 2, and the components and functions of the test setup are shown in Table 1.

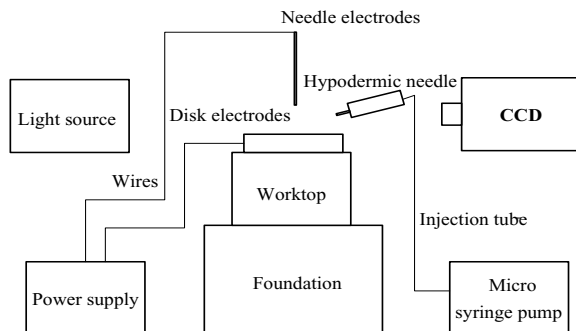

Fig. 2. Schematic diagram of the experimental setup.

Table 1. Components and functions of the test set.

Serial number	Testing Instruments	Functionality
1	DC power supply	Provides 0-30kV DC voltage
2	Needle Electrodes	Connects to the positive pole of the power supply
3	Disk Electrodes	Connect to the negative pole of the power supply
4	Hypodermic needle	Teardrop
5	Micro-flow syringe pumps	Injection of water droplets onto the surface of acetate film
6	CCD camera	Taking pictures of water droplet changes
7	LED cold light source	Enhances the clarity of captured videos

3.2 Experimental process

A schematic diagram of droplet measurement on a solid surface is shown in Fig. 3. The acetate film was placed on the disk electrode, and water droplets were injected onto the surface of the acetate film by a micro-flow syringe pump, controlling the volume of water to be 5 μ L. Turn on the switch of the LED cold light source, and take pictures of the droplet morphology with a CCD camera. Turn on the high-voltage DC power supply, apply 1kV voltage to the droplet, at this time the field strength is 1kV/cm, the contact angle of the droplet changes, wait for the droplet to stabilize, and then take pictures of the droplet morphology with a CCD camera. Turn off the DC power supply, the droplet contact angle slowly recovered, wait for the droplet to stabilize, and then use the CCD camera to take pictures of the droplet topography. Repeat the above steps and take pictures of the droplet shape when the voltage is applied and turned off at 2 kV, 3 kV, 4 kV and 5 kV. The contact angle of the test pictures was measured with a contact angle meter for five times, and the average values are shown in Table 2.

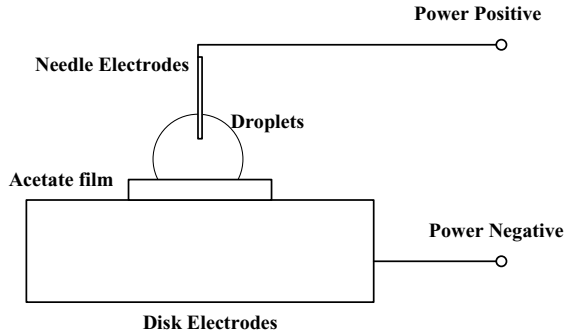

Fig. 3. Schematic diagram of droplet measurement.

Table 2. Data of droplet contact angle variation with voltage.

Electric field strength (kV/cm)	Contact angle before applying voltage (°)	Contact angle after applying voltage (°)	Contact angle after switching off voltage (°)
1 kV	152.6	142.3	146.8
2 kV	152.6	126.4	145.2
3 kV	152.6	101.5	144.9
4 kV	152.6	96.6	142.7
5 kV	152.6	92.7	141.6

4. Experimental results and analysis

Analyzing the experimental data, it was found that the law of change of water droplets with electric field strength as shown in Fig. 4.

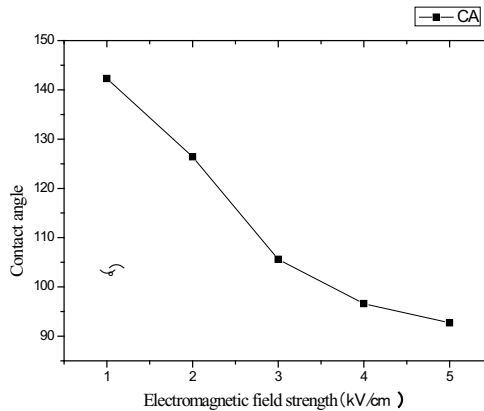

Fig. 4. Variation curve of droplet contact angle with electric field strength.

When the electric field strength was zero, the contact angle of the water droplet was 152.6°. The contact angle of the water droplet decreased with the increase of the applied electric field strength. When the electric field strength was 5 kV/cm, the contact angle was 92.7°. When the electric field strength was 1kV/cm, the contact angle was 142.3°. When

the DC power supply is turned off, the contact angle of the droplet gradually recovers, but it cannot be completely restored to the original value.

5 Conclusion

(1) Preparation of superhydrophobic acetate films by electrostatic spinning, the maximum contact angle for a 5 μ L water droplet was 152.6°.

(2) It was found that the contact angle of water droplet on the superhydrophobic surface decreases with the increase of the electric field strength. When the electric field strength varies in the range of 1-5 KV, the contact angle of the water droplet varies in the range of 92.7-142.3°. When the DC power supply is turned off, the contact angle of the water droplet gradually recovers, but it cannot be fully restored to its original state.

This research was supported by Jilin Province Natural Science Foundation (Grants No. 20220101246JC).

References

1. Jiang Lei, Feng Lin. *Bionic Smart Nano Interface Materials*, Chemical Industry Press, (2007).
2. Chamakos NT, Karapetsas G, Papathanasiou AG, Effect of substrate topography, material wettability and dielectric thickness on reversible electrowetting, *Colloids and Surfaces A: Physicochemical and Engineering Aspects*, , 555:595-604(2018).
3. Athanasios G. Papathanasiou. Progress toward reversible electrowetting on geometrically patterned superhydrophobic surfaces. *Current Opinion in Colloid & Interface Science*, 2018, 36:70-77 (2018).
4. B. Berge, J. Peseux. Variable focal lens controlled by an external voltage: An application of electrowetting. *The European Physical Journal E*, 3(2): 159-162(2000).
5. Chen X, Jiang H, Hayes R A, et al. Screen printing insulator coatings for electrofluidic display devices. *Physica Status Solidi Applications & Materials*, 212(9): 2023-2030(2015).
6. Chen X, He E T, Jiang H, et al. Screen-printing fabrication of electrowetting displays based on poly(imide si-loxane) and polyimide. *Displays*, 37: 84-91(2015).
7. Wen C, Ren J, Xia J, et al. Self-assembly oil-water perfusion in electrowetting displays. *Journal of Display Technology*, 9(2) : 122-126(2013).
8. S. Agarwal, A. Greiner, J. H. Wendorff. Functional materials by electrospinning of polymers. *Progress in Polymer Science*, 38(6): 963-991(2013).
9. W. E. Teo, S. Ramakrishna. A review on electrospinning design and nanofibre assemblies. *Nanotechnology*, 17(14): 89(2006).